

Level Measurement

Point level measurement - Vibrating switches

SITRANS LVL100

Overview



SITRANS LVL100 is a compact vibrating level switch for use in liquid and slurry applications such as overflow, high, low and demand applications, as well as pump protection. It is ideal for use in confined spaces.

Benefits

- Proven vibrating level switch technology for liquids
- Compact insertion length of 40 mm (1.57") for confined space applications
- Fault monitoring for corrosion, loss of vibration, or line break to the piezo drive
- Integrated test function to confirm correct operation

Application

SITRANS LVL100 is a compact level switch designed for industrial use in all areas of process technology and can be used with liquids and slurries. With an insertion length of only 40 mm (1.57"), SITRANS LVL100 can be mounted in small pipes and confined space applications. It is virtually unaffected by the chemical and physical properties of the liquid. The LVL100 can be used in difficult conditions including turbulence, air bubbles, foam generation, buildup, or strong external vibration.

The tuning fork is piezoelectrically energized and vibrates at a mechanical resonance frequency of approximately 1200 Hz. The vibration frequency changes when the tuning fork is covered by the medium. This change is detected by the integrated oscillator and converted into a switching command. The integrated electronics evaluate the level signal and output a switching signal to connected devices.

- Key Applications: For use in liquids and slurries, for level measurement, overflow, and dry run protection

Configuration

Horizontal mounting

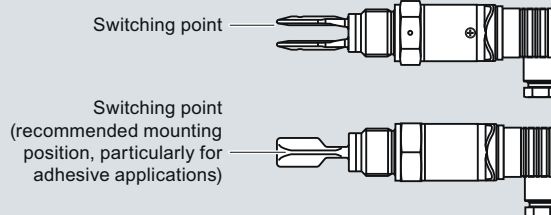

Vertical mounting

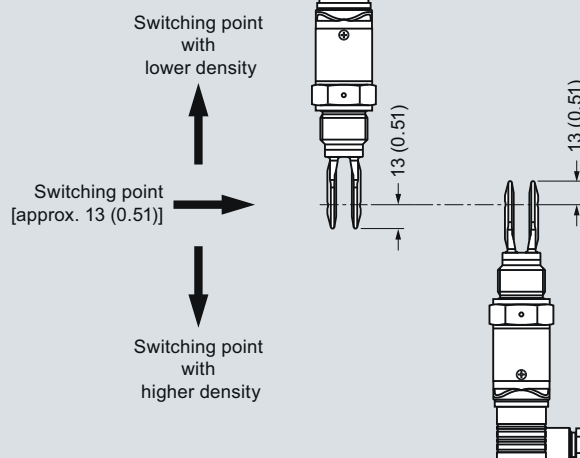

Horizontal mounting in viscous or adhesive applications

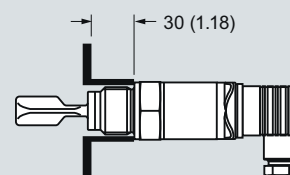

Moisture protection

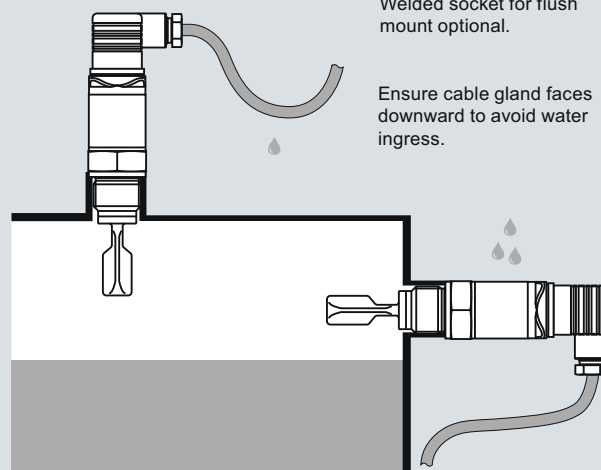

SITRANS LVL100 Installation, dimensions in mm (inch)

Level Measurement

Point level measurement - Vibrating switches

SITRANS LVL100

Technical specifications

Mode of operation

Measuring principle Vibrating point level switch

Input

Measured variable High and low and demand

Output

Output options Contactless electronic switch
Transistor output PNP

Measuring Accuracy

Hysteresis approx. 2 mm (0.08") with vertical installation

Switching delay approx. 500 ms (on/off)

Frequency approx. 1200 Hz

Rated operating conditions

Installation conditions

• Location Indoor/outdoor

Ambient conditions

• Ambient temperature -40 ... +70 °C (-40 ... +158 °F)

• Installation category III

• Pollution degree 2

Medium conditions

• Temperature

- Standard -40 ... +100 °C (-40 ... +212 °F)

- High temperature option -40 ... +150 °C (-40 ... +302 °F)

• Pressure (vessel) -1 ... 64 bar g (-14.5 ... 928 psi g)

• Density 0.7 ... 2.5 g/cm³
(0.025 ... 0.09 lbs/in³)

Design

Material

• Enclosure 316L and Plastic PEI

• Tuning fork 316L (1.4404 or 1.4435)

• Process connection (threaded) 316L (1.4404 or 1.4435)

• Process seal Klingersil C-4400

Process connection

• Pipe thread, cylindrical (ISO 228 T1) G ¾" A or G 1" A

• Pipe thread, tapered ¾" NPT or 1" NPT

• Hygienic fittings Bolting DN40 PN40

Tri-clamp 1", 1½", 2" PN 10

Degree of protection IP65/Type 4/NEMA 4 (with DIN 43650 valve plug), IP66/67 or IP68 (with M12 connector)

Conduit entry 1 x M12 [IP66/IP67 or IP68 (0.2 bar)]

Weight (housing) 250 g (9 oz)

Power supply

Supply voltage 20 ... 253 V AC, 50/60 Hz
20 ... 253 V DC

Power consumption 1 ... 8 VA (AC), approx. 1.3 W (DC)

Certificates and approvals

Overfill protection (WHG)

Shipping approvals

Options

LVL100 Threaded Welded Socket

G¾" A/316L

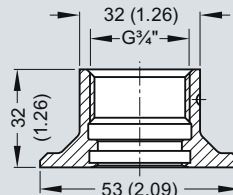

G1" A/316L

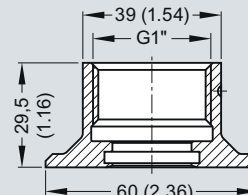

SITRANS LVL100 welded socket, dimensions in mm

Level Measurement

Point level measurement - Vibrating switches

SITRANS LVL100

Selection and Ordering data	Order No.	Selection and Ordering data	Order code
SITRANS LVL100 Compact vibrating level switch for use in liquid and slurry applications such as overflow, high, low and demand applications, as well as pump protection. Ideal for use in confined spaces.	7 ML 5 7 4 5 -	Further designs Please add "-Z" to Order No. and specify Order code(s).	
Approvals Without approvals Shipping approvals ¹⁾ Overfill protection (WHG) ²⁾	A 0 1 2 3	Cleaning including Certificate (oil, grease and sili-cone free) Identification Label, foil laser marking Acceptance test certificate 3.1 for instrument Acceptance test certificate 2.2 for instrument	W01 Y16 C12 C14
Process temperature Standard -40 ... +100 °C (-40 ... +212 °F) ³⁾ Extended -40 ... +150 °C (-40 ... +302 °F) ³⁾ Hygienic applications -40 ... +150 °C (-40 ... +302 °F) ⁴⁾	A B C	Additional Operating Instructions LVL 100 (Contactless electronic switch)	Order No.
Process connection Thread G $\frac{3}{4}$ " A PN64/316L Thread G $\frac{3}{4}$ " A PN64/316L Ra< 0.8 μm^5 Thread $\frac{3}{4}$ " NPT PN64/316L Thread $\frac{3}{4}$ " NPT PN64/316L Ra< 0.8 μm^5 Thread G1" A PN64/316L Thread G1" A PN64/316L Ra< 0.8 μm^5 Thread G1" A PN64/316L Ra< 0.8 μm^5 Thread 1" NPT PN64/316L Thread 1" NPT PN64/316L Ra< 0.8 μm^5 Tri-Clamp 1" PN16 DIN 32676/316L Ra< 0.8 μm^5 Tri-Clamp 1 $\frac{1}{2}$ " PN16 DIN 32676/316L Ra< 0.8 μm^5 Tri-Clamp 2" PN16 DIN 32676/316L Ra< 0.8 μm^5 Bolting DN25 PN40 DIN 11851/316L Ra< 0.8 μm^5 Bolting DN40 PN40 DIN 11851/316L Ra< 0.8 μm^5 Bolting DN50 PN25 DIN 11851/316L Ra< 0.8 μm^5 SMS DN38 PN6 SMS1145/316L Ra< 0.8 μm^5 Hygienic fitting with compression nut F40 ⁵⁾ PN25/316L Ra < 0.8 μm	A 0 A 1 A 2 A 3 A 4 A 5 A 6 A 7 A 8 B 0 B 1 B 2 B 3 B 4 B 5 B 6	• English • French • Spanish • German LVL 100 (Transistor PNP) • English • French • Spanish • German This device is shipped with the Siemens Milltronics manual CD containing the complete Operating Instructions library.	7ML1998-5KN01 7ML1998-5KN11 7ML1998-5KN21 7ML1998-5KN31 7ML1998-5KP01 7ML1998-5KP11 7ML1998-5KP21 7ML1998-5KP31
Electronics Contactless electronic switch 20 ... 250 V AC/DC ⁶⁾ Transistor output PNP 10 ... 55 V DC	1 2	Spare Parts LVL 100 Threaded Welded Socket G $\frac{3}{4}$ " A/316L with FKM Seal G 1 A/316L with FKM Seal M27x1.5/316L with FKM Seal G $\frac{3}{4}$ " A/316L with EPDM Seal G 1 A/316L with EPDM Seal M27x1.5/316L with EPDM Seal	7ML1930-1EE 7ML1930-1EF 7ML1930-1EG 7ML1930-1EH 7ML1930-1EJ 7ML1930-1EK
Housing 316L	1		
Electrical connection/Protection M12x1/IP67 According to DIN 43650 including plug/IP65 Acc. to DIN 43650 incl. plug with QuickOn connection/IP65 M12x1 incl. 5 m cable/IP68 (0.2 bar)	A B C D		

- 1) Available with Process Temperature option A only
- 2) Available with Electronics option 2 only
- 3) Available with process connection A0, A2, A4, and A6 only
- 4) Available with process connection A1, A3, A5, and A7 to B6 only
- 5) Available with Process Temperature option C only
- 6) Available with Electrical connection/Protection option B and C only

Level Measurement

Point level measurement - Vibrating switches

SITRANS LVL100

Characteristic curves

Ambient Temperature to Process Temperature dependency
(Standard version)

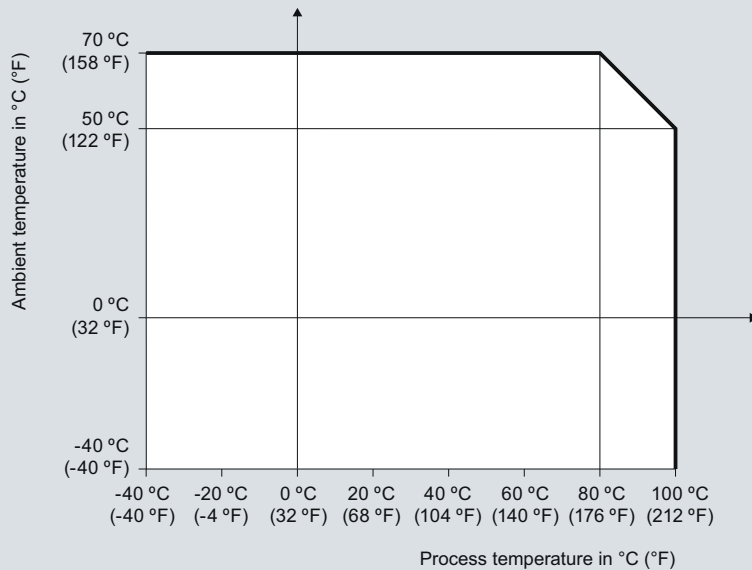

Ambient Temperature to Process Temperature dependency
(High temperature version)

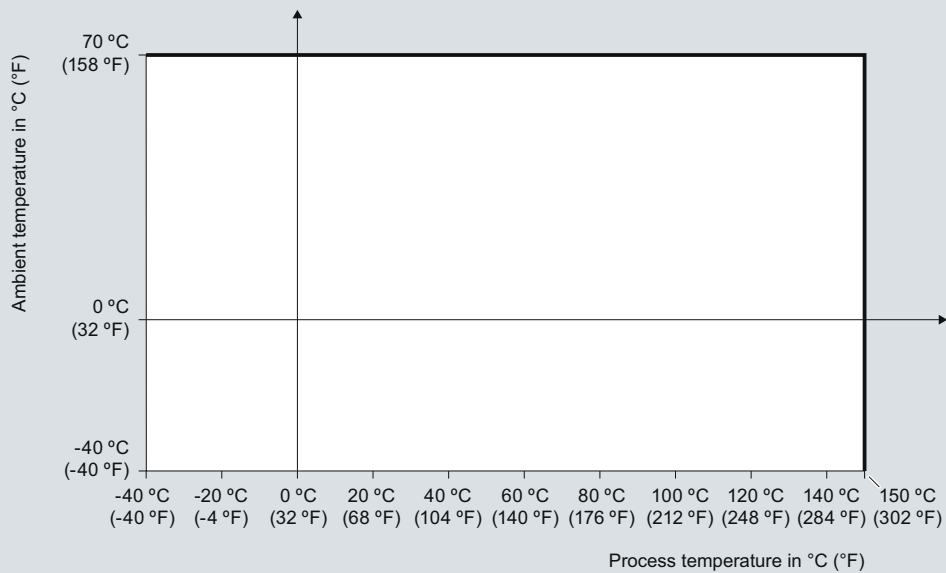

SITRANS LVL100 Ambient Temperature/Process Temperature derating curves

Level Measurement

Point level measurement - Vibrating switches

SITRANS LVL100

Dimensional drawings

SITRANS LVL100 (standard)

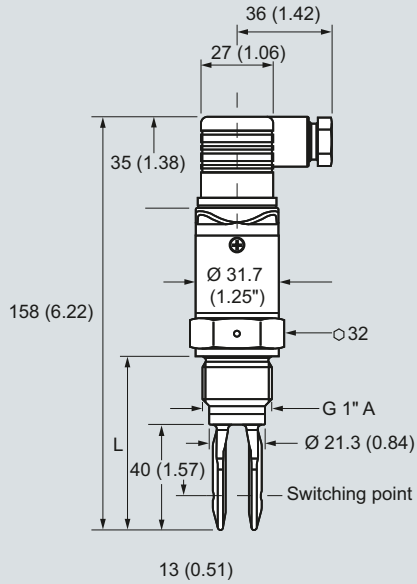

L =
 Length with G 3/4" A, 3/4" NPT: 66 (2.6)
 Length with G 1" A, 1" NPT: 69 (2.7)

SITRANS LVL100 (extended)

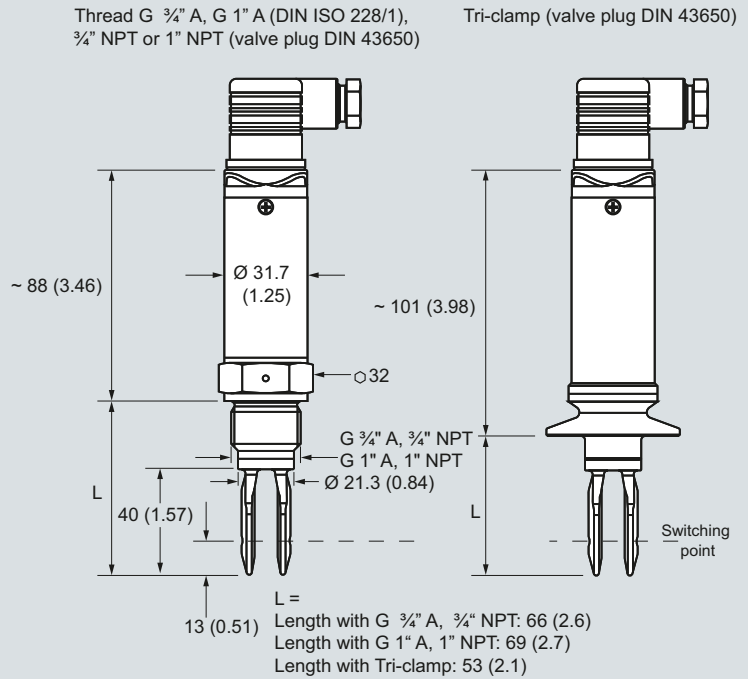

L =
 Length with G 3/4" A, 3/4" NPT: 66 (2.6)
 Length with G 1" A, 1" NPT: 69 (2.7)
 Length with Tri-clamp: 53 (2.1)

SITRANS LVL100 (standard with M12 connector)

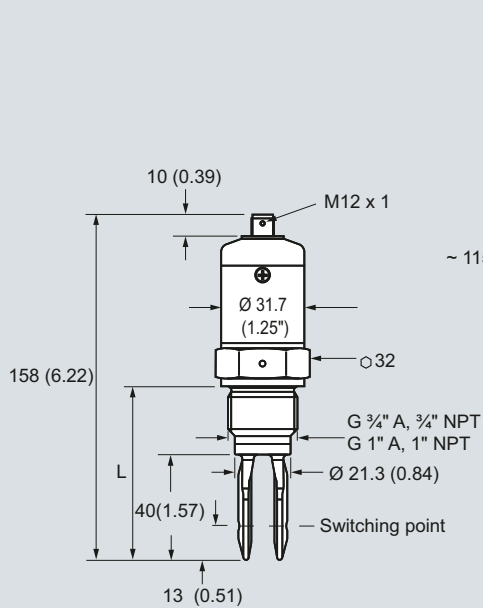

L =
 Length with G 3/4" A, 3/4" NPT: 66 (2.6)
 Length with G 1" A, 1" NPT: 69 (2.7)

SITRANS LVL100 (extended, high temperature)

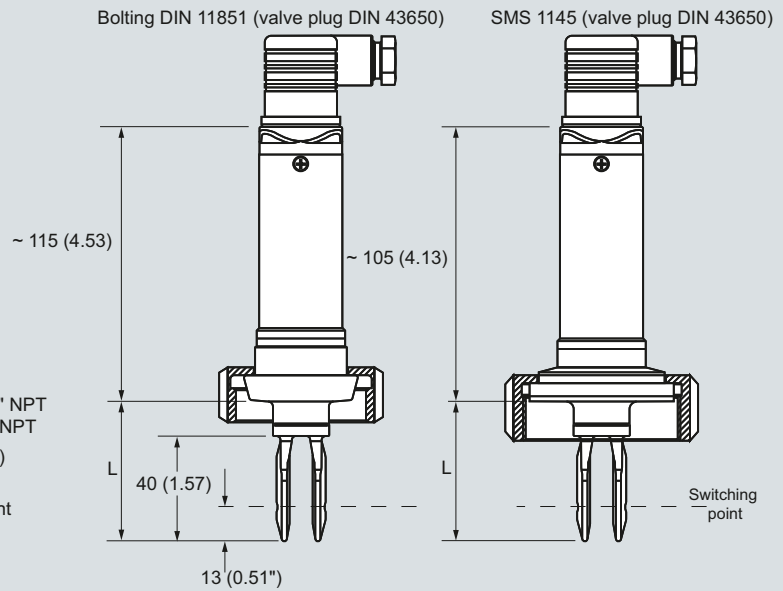

L =
 Length with bolting: 53 (2.1)
 Length with SMS 1145: 53 (2)

SITRANS LVL100, dimensions in mm (inch)

Level Measurement

Point level measurement - Vibrating switches

SITRANS LVL100

Schematics

Transistor PNP (M12 x 1 Plug connection)

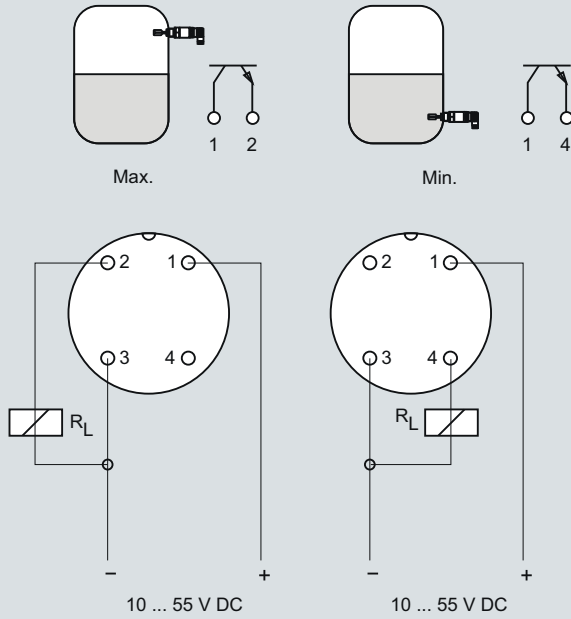

Transistor PNP (with valve plug DIN 43650)

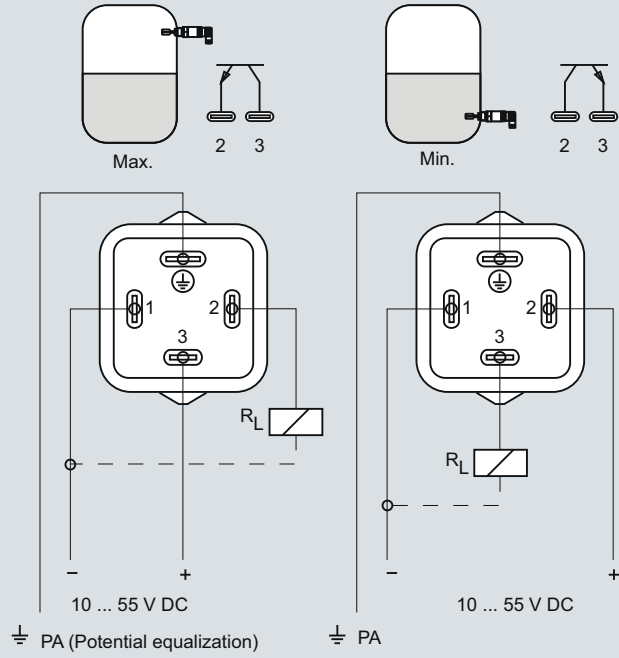

Contactless electronic switch (Valve plug DIN 43650)

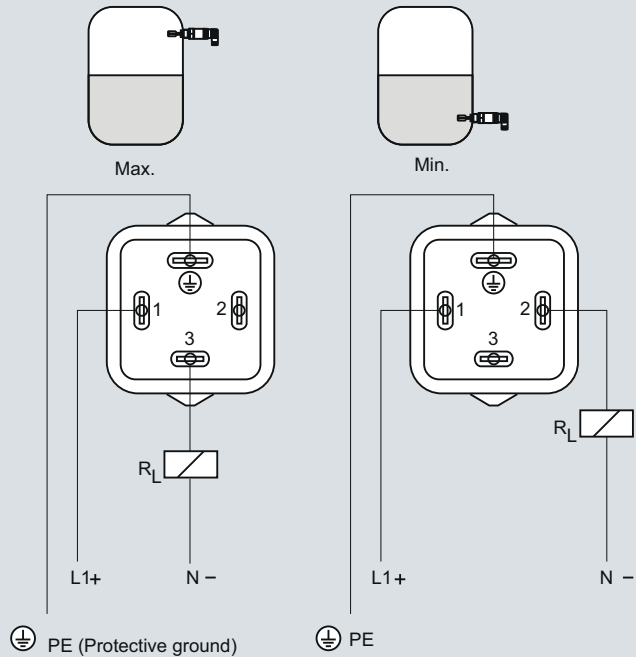

SITRANS LVL100 connections

5